

AIRSYS



OPTIMA-INV DXA

Precision Cooling Technology for
Critical Applications

Cooling Capacity: 5.6kW-104.6kW

www.air-sys.uk



The OPTIMA product family from Airsys is designed specifically for use within small, medium and large data centres, as well as for process and cleanroom applications. OPTIMA units combine precise temperature and humidity control with outstanding reliability.

OPTIMA INV-DXA is a DX air-cooled system that is optimised to deliver energy efficient solutions utilising EC fan and inverter compressor technology as standard. With options to combine DX-based cooling with Airsys leading edge direct free-cooling technology, allowing you to exploit low ambient conditions and maximise your energy savings.

Unit Identification

01	02	03	04	05	06	07	08	09	10	11	12	13	14	15	16
OPTIMA-INV	.	Default	.	O	.	DXA	16	E1	A1	R410	.	380/3/50	FEA	.	XXX

01	OPTIMA	Product series name: OPTIMA: Precision air conditioner
02	.	Separator Character ""
03	Default	Without free cooling or dual cooling sources FC - Indirect free cooling DC - Dual cooling sources DFC - Direct free cooling
04	.	Separator Character ""
05	O/U	O: Upflow U: Downflow
06	.	Separator Character ""
07	DXA	Direct expansion with air cooled condenser
08	20	Nominal cooling capacity: kW
09	V1	V1 - OPTIMA-INV 1 compressor V2 - OPTIMA-INV 2 compressors
10	A1	Cabinet size code: "A" cabinet with 5 sizes A1-A5.
11	R410	Refrigerant: R410A
12	.	Separator Character ""
13	380/3/50	Power source: Voltage/Phase/Frequency Default= 380/3/50
14	FEA	Fan type: FEA-EC supply fan, AMAE series outdoor unit
15	.	Separator Character ""
16	XXX	Code for custom design

Engineered features

1 Precise control

The control accuracy for temperature is $\pm 1^{\circ}\text{C}$ and for relative humidity is $\pm 5\%$.

2 Various supply air arrangements

Supply air arrangements include top discharge (upflow) and bottom discharge (downflow). Return air arrangements include top return, bottom return, front return and rear return, to meet all site requirements.

3 Corrosion-proof

The unit framework is provided with a corrosion protection treatment. The treatment is sufficient to provide protection for a 15 year life cycle for inland installation. If necessary, the treatment for sea air environment can be supplied as an option.

4 Easy maintenance

The technical compartment housing the compressor, humidifier, control and safety devices is separated from the air flow, enabling ordinary service and preventative maintenance to occur during operation.

5 EC Fan

Highly efficient EC fans are supplied with OPTIMA products.

6 Air Filter

A washable, easily maintainable and durable G4 class air filter is a standard configuration for the OPTIMA range. With optional air pressure switch, a clogged filter alarm can be triggered when the filter is dirty.

7 Scroll compressor

OPTIMA (DXA & DXW) units are equipped with scroll compressors which produce less vibration, lower noise and greater efficiencies.

8 Isolated control panel

All the electrical and control components are installed in an isolated control panel with orderly wiring and clear labelling, meeting the IEC standards.

9 Forced dehumidification system

The dehumidification process occurs through decreasing the evaporator coil surface temperature or reducing the air flow across the coil. Variable-capacity systems come with power monitoring tools that are displayed locally, in addition to being available via remote access. Power monitoring can be used to measure efficiencies across systems, regions and networks. This feature can be used for predictive maintenance.

10 Electrode Humidifier (optional)

An electrode humidifier, controlled by a microprocessor, monitors and adjusts the humidifying capacity precisely, while the water quality monitoring and wash extends the maintenance interval, prolonging the working life of the unit.

11 Electric Heater (optional)

The construction of the electric heater element (stainless steel pipe with wrapped fins) allows for a reduced operating temperature, therefore eliminating ionisation, and avoiding unpleasant odors.

12 Self-diagnosis

All the microprocessor-connected components are continuously monitored and controlled and, in case of malfunction, the unit is shut down and the fault is shown on the display.

Working Flow Schematic Diagram

Air cooled direct expansion system (DXA)

Heat from the indoor air is transferred to the refrigerant at the evaporator coil and rejected to the outside air via the air-cooled condenser.

Air cooled direct expansion (DXA) includes throttle, evaporator coil, scroll compressor and refrigeration piping configuration.

Indoor unit: OPTIMA(-INV).DXA

Outdoor unit: AMAE air cooled condenser

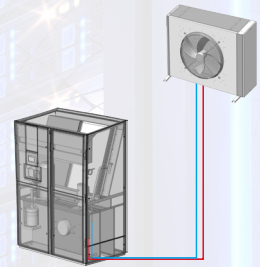

Air cooled direct expansion with indirect free cooling (FC.DXA)

The FC.DXA unit is a dual-circuit system combining DXA heat-rejection with indirect free cooling (FC). The circuits are independent.

When there is a call for cooling, and the difference between indoor and ambient temperatures is acceptable, the FC unit will run to provide indirect free cooling through rejecting heat via a dry cooler. Only when free cooling capacity is insufficient to meet the cooling demand will the DXA unit start up mechanical cooling. Reduced run hours of the DXA system through the use of the FC unit saves energy.

Indoor unit: OPTIMA(-INV)-FC.DXA

Outdoor unit: AMAE air cooled condenser, CMEH dry cooler, PUG pump kit

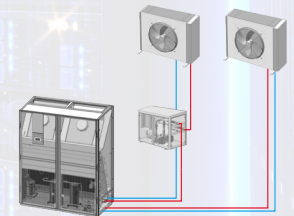

Air cooled direct expansion with double cooling source (DC.DXA)

The DC.DXA unit is a dual-circuit system offering both DXA (air cooled) mechanical cooling and chilled water cooling (CW). It contains two independent cooling circuits with different heat-rejection methods for redundancy.

Indoor unit: OPTIMA(-INV)-DC.DXA

Outdoor unit: AMAE air cooled condenser, PUG pump kit, CMEH dry cooler, user supplied chilled water source

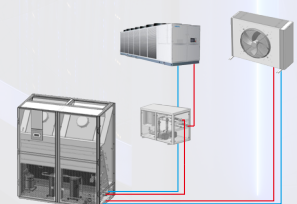

Direct Free Cooling (DFC)

For installations where outdoor temperatures are commonly lower than indoor temperature, fresh air can be introduced directly into the room to cool the equipment; this is known as direct free cooling (DFC). A well designed and integrated DFC system can greatly reduce the dependency on other cooling systems and save energy through minimizing their run hours. DFC systems can be integrated with OPTIMA-INV units, with both up flow and down flow configurations. The corresponding series name becomes OPTIMA-INV-DFC.DXA. The diagram showing the arrangement and principle for direct free cooling options is as follows:

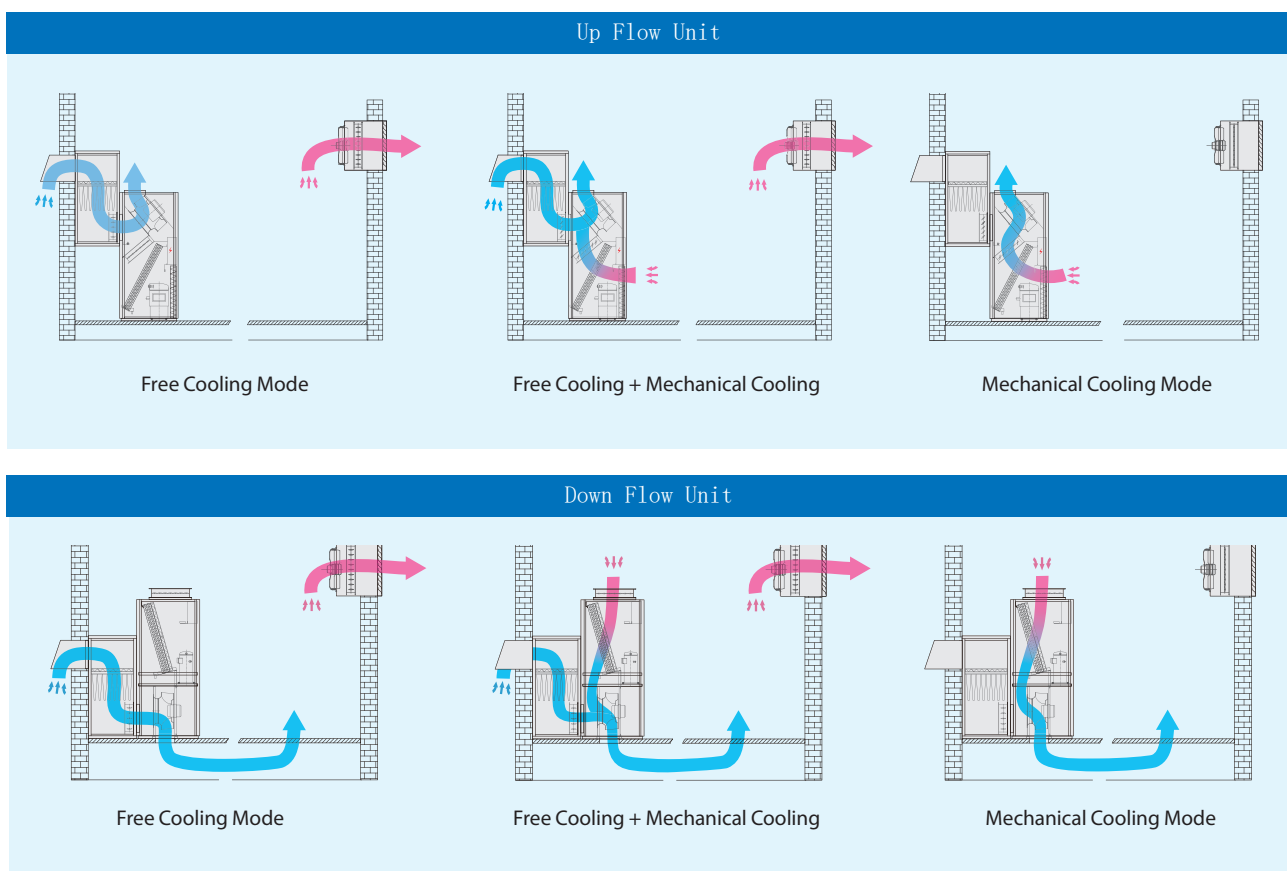

OPTIMA-INV-DFC systems include mechanical (DX) cooling and free cooling modes, together with the intelligence to switch between the modes to ensure the most efficient operation. When utilizing direct free cooling, the DX system compressor stops, which has a significant impact on the energy consumption.

In recent years, energy-efficient data centers have attracted greater attention and many data centers are now able to achieve significant energy savings through both increasing the IT equipment tolerance temperatures and expanding the considered geographical scope to exploit direct free cooling (which is not only limited to regions of extreme cold).

Indirect Free Cooling

Indirect free cooling refers to heat-rejection through circulating water between an indoor cooling coil and an outdoor dry cooler or cooling tower; the water absorbs the heat at the indoor coil and then discharges it to the atmosphere via the dry cooler or cooling tower.

Air cooled direct expansion unit with indirect free cooling(FC)

By adding a water coil to the direct-expansion evaporator coil and completing an indirect free cooling (FC) circuit with a dry cooler or cooling tower, significant energy savings can be made through a reduction in the DX compressor run hours. When there is a call for cooling, and the difference between indoor and ambient temperatures is acceptable, the FC system will run to provide indirect free cooling. If the FC system can not satisfy the total cooling demand, the DX cooling system will commence operation, however, as the outdoor ambient temperature decreases, the proportion of FC capacity will increase. When free cooling capacity reaches 100%, and cooling demand is being met, complete FC mode is achieved and there is no compressor power consumption from the DX system.

OPTIMA-INV units can accommodate the indirect free cooling option. The corresponding series becomes OPTIMA-INV-FC.DXA.

The schematic diagram showing the principle of operation for an air-cooled direct expansion unit with indirect free cooling (FC) is as follows:

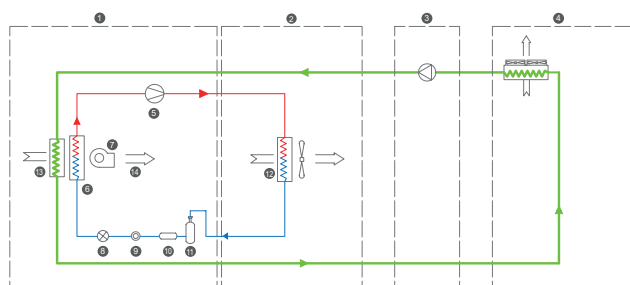

- | | |
|------------------------|-------------------------|
| 1 Indoor unit | 8 Expansion valve |
| 2 Outdoor unit | 9 Sight glass |
| 3 Pump group(optional) | 10 Filter dryer |
| 4 Dry cooler(optional) | 11 Liquid receiver |
| 5 Compressor | 12 Air cooled condenser |
| 6 Evaporator | 13 Return air |
| 7 Supply fan | 14 Supply air |

Technical Parameters

OPTIMA-INV.DXA

Unit model		16V1A1	20V1A1	25V1A1	30V1A2	35V1A2	40V1A3
Supply air scheme(1)		O/U					
Cooling capacity							
Total (2)	kW	16.3	22.3	25.1	30.2	36.9	40.6
Sensible (2)	kW	15.0	20.7	23.3	27.5	34.0	38.2
Total (3)	kW	17.9	24.5	27.6	33.2	40.6	44.7
Sensible (3)	kW	16.0	22.2	24.9	29.4	36.4	40.9
Compressor							
Type		Hermetic inverter scroll					
Power input (2)	kW	4.2	5.9	7.1	7.9	9.2	10.6
Current (2)	A	6.8	9.5	11.4	12.7	14.7	17
Max power input (4)	kW	6.8	11.5	11.5	13.7	15.2	11.5
Max current input (4)	A	10.9	18.4	18.4	22.0	24.5	18.5
Supply fan							
Type		Caseless backward EC centrifugal fan					
Qty. of fan	n.	1	1	1	1	1	2
Air volume	m ³ /h	5750	6500	7300	8800	9600	12600
Extra pressure (5)	Pa	Standard ESP is 75Pa, adjustment range is 50~300Pa					
Power input	kW	1.1	1.25	1.46	1.7	2.0	2.4
Current	A	1.7	2	2.3	2.6	3.	3.7
Condenser fan (3)							
MAE Model		AMAE6	AMAE6	AMAE8	AMAE10	AMAE12	AMAE15
Quantity	n.	1	1	1	1	1	1
Electric heater							
Type	kW	6	6	9	9	9	13.5
Heating capacity	A	9.1	9.1	13.5	13.5	13.5	20.4
Working steps	n.	2	2	2	2	2	2
Humidifier							
Type		Electrode					
Capacity	kg/h	3	3	5	5	5	8
Power input	kW	2.3	2.3	3.8	3.8	3.8	5.9
Current	a	3.4	3.4	5.7	5.7	5.7	9
Power supply							
Power supply		380V/3Ph/50Hz					
Unit maximum operating power input(6)	kW	17.0	21.7	24.7	26.9	33.6	33.4
Unit maximum operating current (6)	A	28.6	36.1	40.5	44.1	56.5	56.1
Air filter							
		G4/plate					
Unit piping connection							
Humidifier water supply	in	1/2					
Condensing water drainage	in	3/4					
Gas pipe	mm	19	22	22	22	22	2x22
Liquid pipe`	mm	12.7	12.7	12.7	16	16	2x12.7
Unit dimension and weight							
Width	mm	875	875	1480	1480	1480	1750
Depth	mm	890	890	890	890	890	890
Height	mm	1960	1960	1960	1960	1960	1960
Weight	kg	280	320	380	420	460	525

(1) — O: Over flow, U: Under flow;

(2) —Return air temperature is 24 , RH50%, Ambient temperature35 , Inverter compressor is under economic speed.

(3) —Return air temperature is 24 , RH50%, Ambient temperature35 , Inverter compressor is under maximum speed.

(4) —Maximum input power of the inverter compressor refers to the input power at the maximum speed of the compressor and at a high condensing temperature. Maximum current value is the input current value from the power source to the inverter drive.

(5) —For ESP over 300 Pa, Contact manufacturer;

(6) —Max operating power and current: in the extreme condition when ambient temperature at 45 and unit's electrical heater running at its full capacity to de-humidify.

Technical Parameters

OPTIMA-INV.DXA

Unit model		45V2A3	55V2A3	60V2A4	70V2A4	80V2A4	90V2A5	100V2A5
Supply air scheme(1)		O/U						
Cooling capacity								
Total (2)	kW	45.0	55.0	61.6	70.8	80.3	90.3	100.8
Sensible (2)	kW	41.5	50.2	56.1	64.4	72.3	82.1	93.5
Total (3)	kW	49.5	60.5	67.8	77.9	88.3	99.3	110.9
Sensible (3)	kW	44.4	53.7	60.0	68.9	77.3	87.9	100.0
Compressor								
Type		Hermetic inverter scroll circuit 1, hermetic fixed speed scroll circuit 2						
Power input (2)	kW	12	13.9	16.2	18.2	20.5	22.2	27.6
Current (2)	A	19.2	31.3	33.5	36.3	40.3	42.5	50.3
Max power input (4)	kW	11.5	13.7	13.7	15.2	15.2	16.7	21
Max current input (4)	A	18.5	22	22.0	24.5	24.5	27	31
Supply fan								
Type		Caseless backward EC centrifugal fan						
Qty. of fan	n.	2	2	3	3	3	3	3
Air volume	m ³ /h	13200	13600	17800	19200	24000	26000	27900
Extra pressure (5)	Pa	Standard ESP is 75Pa, adjustment range is 50~300Pa						
Power input	kW	2.5	2.7	3.4	3.7	5.1	5.6	6.4
Current	A	3.9	4.1	5.2	5.7	7.8	8.7	9.9
Condenser fan (3)								
MAE Model		AMAE6	AMAE8	AMAE10	AMAE12	AMAE15	AMAE18	AMAE20
Quantity	n.	2	2	2	2	2	2	2
Electric heater								
Type	kW	13.5	13.5	18	18	18	18	18
Heating capacity	A	5.9	5.9	5.9	5.9	5.9	5.9	5.9
Working steps	n.	2	2	2	2	2	2	2
Humidifier								
Type		Electrode						
Capacity	kg/h	8	8	8	8	8	8	8
Power input	kW	5.9	5.9	5.9	5.9	5.9	5.9	5.9
Current	a	9	9	9	9	9	9	9
Power supply								
Power supply		380V/3Ph/50Hz						
Unit maximum operating power input (6)	kW	33.4	35.6	43.6	46.5	46.5	48.0	52.3
Unit maximum operating current (6)	A	56.1	59.6	72.1	74.6	74.6	77.1	81.1
Air filter								
		G4/plate						
Unit piping connection								
Humidifier water supply	in	1/2						
Condensing water drainage	in	3/4						
Gas pipe	mm	2x22	2x22	2x22	2x25.4	2x25.4	2x25.4	2x25.4
Liquid pipe ^e	mm	2x12.7	2x16	2x16	2x16	2x19	2x19	2x19
Unit dimension and weight								
Width	mm	1750	1750	2490	2490	2490	3095	3095
Depth	mm	890	890	890	890	890	890	890
Height	mm	1960	1960	1960	1960	1960	2050	2050
Weight	kg	530	550	700	770	790	980	1000

Technical Parameters

OPTIMA-INV(-DFC/FC/DC).DXA

Unit model		16V1A1	20V1A1	26V1A1	30V1A2	35V1A2	40V1A3
Supply air scheme(1)		O/U					
Cooling capacity							
Total (2)	kW	18.2	23.0	28.9	34.0	37.0	41.3
Sensible (2)	kW	16.4	20.7	26.0	30.6	33.3	37.2
FC unit free cooling/DC unit cooling coil capacity							
Total (3)	kW	18.6	22.9	29.6	37.3	40.5	43.6
Sensible (3)	kW	16.7	20.6	26.3	33.2	36.0	39.7
DFC unit free cooling capacity							
Free cooling (4)	kW	9.7	10.7	15.0	16.2	16.2	21.3
Free cooling (5)	kW	19.4	21.3	30.1	32.4	32.4	42.5
Compressor							
Type		Hermetic inverter scroll					
Power input (2)	kW	3.6	4.6	5.8	7.0	7.5	8.5
Supply fan							
Type		Caseless backward EC centrifugal fan					
Qty. of fan	n.	1	1	1	1	1	2
Air volume	m ³ /h	5750	6320	8900	9600	9600	12600
External static (7)	Pa.	Standard ESP is 75Pa, adjustment range is 50~300Pa					
Power input	kW	1.0	1.2	1.4	1.7	1.7	2.4
Noise level (8)							
	dB	63	63	63	66	66	66
Electric heater							
Type		Stainless steel					
Heating capacity	kW	6	6	9	9	9	13.5
Working steps	n.	2	2	2	2	2	2
Air filter							
		G4/plate					
Humidifier							
Type		Electrode					
Capacity	kg/h	3	3	5	5	5	8
Power input	kW	2.3	2.3	3.8	3.8	3.8	5.9
Air condenser (10)							
Model*Qty		AMAE5*1	AMAE6*1	AMAE8*1	AMAE10*1	AMAE12*1	AMAE12*1
Dry cooler (only available for FC unit)							
Model		CMEH20	CMEH30	CMEH30	CMEH40	CMEH50	CMEH60
Qty		1	1	1	1	1	1
FC unit free cooling coil/DC unit chilled water coil							
Water flow	m ³ /h	3.2	4.1	5.2	6.7	7.1	7.5
Pressure drop	kPa	54.2	45.2	56.4	63.1	69.2	56.7
DFC unit fresh air inlet box (11)							
Model*Qty		S1*1	S1*1	S2*1	S2*1	S2*1	S1*2
DFC unit air outlet box (12)							
Model*Qty		B*1	B*1	B*1	B*1	B*1	B*2
Power supply							
Power source		380V/3Ph/50Hz					

(1) O:Up flow; U:Down flow;

(2) Return air dry bulb temperature 24 , RH50%, condensing temperature 47 ;

(3) Return air dry bulb temperature 24 , RH50% inlet/outlet chilled water temperature 7 /12 ;

(4) The cooling capacity@indoor temperature and outdoor temperature difference (ΔT) is 5 , compressor not operating;

(5) The cooling capacity@indoor temperature and outdoor temperature difference (ΔT) is 10 , compressor not operating;

(6) For dual refrigerating circuit units, including a hermetic fixed frequency scroll compressor except for a hermetic inverter scroll compressor;

(7) For ESP over 300 Pa, Contact manufacturer;

(8) Tested at 1m distance, free field;

(9) The default capacity, please refer to "electric heater/ humidifier selection sheet" for other capacity;

(10) CME adopts AC fan, AMAE adopts EC fan, choose according to demand;

(11) Packaged individually, please refer to "DFC Fresh Air Inlet Box" for specific parameters;

(12) Optional.

Technical Parameters

OPTIMA-INV(-DFC/FC/DC).DXA

Unit model		45V2A3	50V2A3	60V2A3	70V2A4	80V2A4	90V2A5	100V2A5
Supply air scheme(1)		O/U						
Cooling capacity								
Total (2)	kW	48.3	52.3	65.6	73.5	84.7	93.7	102.3
Sensible (2)	kW	43.5	47.1	59.0	66.2	76.2	84.3	92.1
FC unit free cooling/DC unit cooling coil capacity								
Total (3)	kW	55.2	55.2	63.1	77.5	84.1	102.5	116.2
Sensible (3)	kW	50.2	50.2	57.4	70.5	75.7	92.3	104.6
DFC unit free cooling capacity								
Free cooling (4)	kW	23.0	23.0	30.1	32.4	35.5	41.5	47.1
Free cooling (5)	kW	45.9	45.9	60.1	64.8	70.9	83.1	94.2
Compressor								
Type		Hermetic inverter scroll circuit 1, hermetic fixed speed scroll circuit 2						
Power input (2)	kW	9.6	10.6	12.9	14.8	17.3	19.1	19.8
Supply fan								
Type		Caseless backward EC centrifugal fan						
Qty. of fan	n.	2	2	3	3	3	3	3
Air volume	m ³ /h	12600	13600	17800	19200	21000	24600	27900
External static (7)	Pa.	Standard ESP is 75Pa, adjustment range is 50~300Pa						
Power input	kW	2.4	2.8	3.6	3.9	4.0	4.2	5.1
Noise level (8)								
	dB	66	66	69	69	69	69	69
Electric heater								
Type		Stainless steel						
Heating capacity	kW	13.5	13.5	18	18	18	18	18
Working steps	n.	2	2	2	2	2	2	2
Air filter								
		G4/plate						
Humidifier								
Type		Electrode						
Capacity	kg/h	8	8	8	8	8	8	8
Power input	kW	5.9	5.9	5.9	5.9	5.9	5.9	5.9
Air condenser (10)								
Model*Qty		AMAE8*2	AMAE8*2	AMAE10*2	AMAE12*2	AMAE15*2	AMAE18*2	AMAE20*2
Dry cooler (only available for FC unit)								
Model		CMEH70	CMEH70	CMEH80	CMEH50	CMEH50	CMEH60	CMEH70
Qty		1	1	1	2	2	2	2
FC unit free cooling coil/DC unit chilled water coil								
Water flow	m ³ /h	9.5	9.5	10.7	13.2	14.2	17.2	19.2
Pressure drop	kPa	51.4	51.4	62.2	54.6	61.3	100.3	118.1
DFC unit fresh air inlet box (11)								
Model*Qty		S1*2	S1*2	S1+S2	S1+S2	S1+S2	S2*2	S2*2
DFC unit air outlet box (12)								
Model*Qty		B*2	B*2	B*2	B*2	B*2	B*3	B*3
Power supply								
Power source		380V/3Ph/50Hz						

Unit Dimension Drawing

A1 Unit cabinet dimension drawing for upflow unit

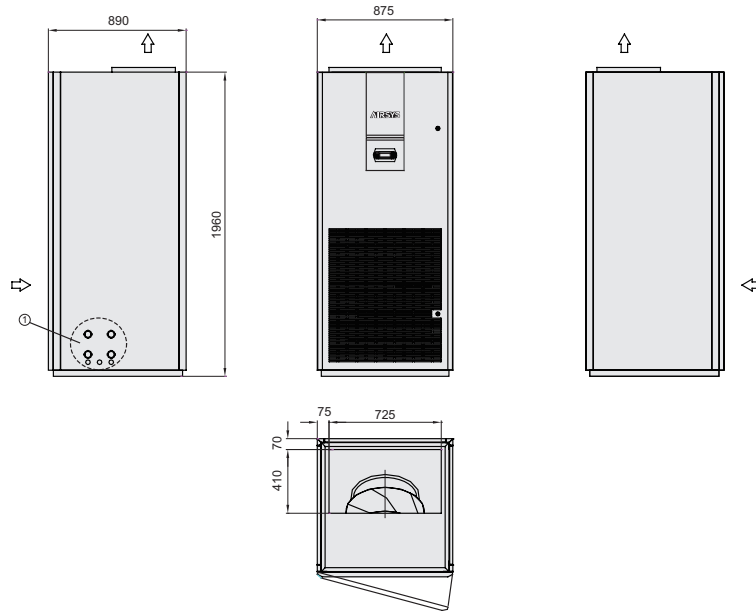

① Pipe connect area: Specific position and kinds differ slightly in different unit series. Refer to the onsite unit.

	A1	A2	A3	A4	A5
WIDTH/mm	875	1480	1750	2490	3095
DEPTH/mm	890	890	890	890	890
HEIGHT/mm	1960	1960	1960	1960	1960

A1 Unit cabinet dimension drawing for underflow unit

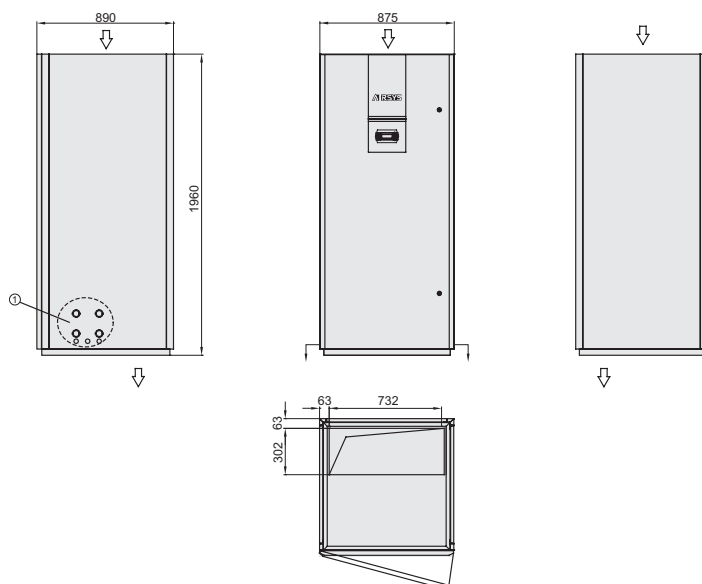

① Pipe connect area: Specific position and kinds differ slightly in different unit series. Refer to the onsite unit.

	A1	A2	A3	A4	A5
WIDTH/mm	875	1480	1750	2490	3095
DEPTH/mm	890	890	890	890	890
HEIGHT/mm	1960	1960	1960	1960	1960

OPTIMA-DFC Fresh air inlet box

S1 Fresh air inlet box

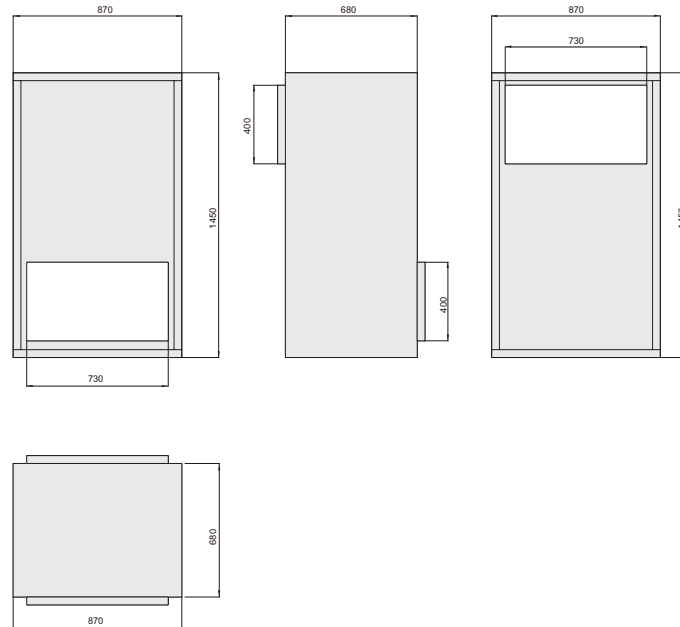

S2 Fresh air inlet box

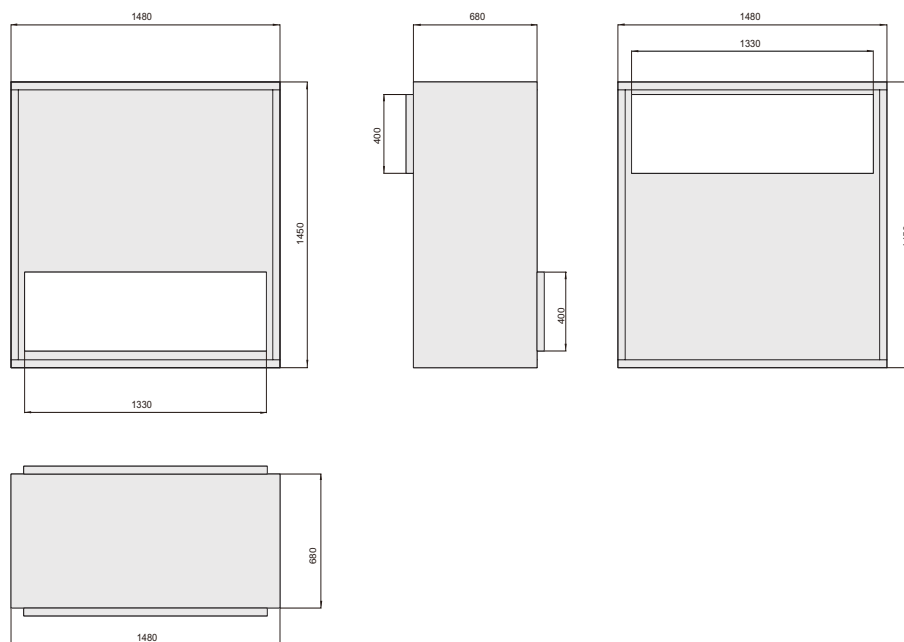

Air cooled condenser

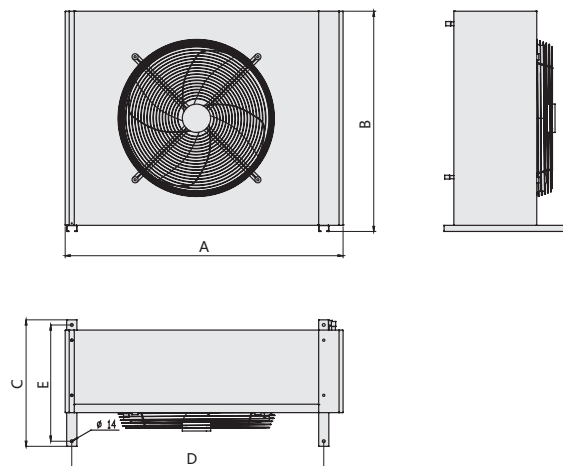

	AMAE5	AMAE6	AMAE8	AMAE10	AMAE12	AMAE15	AMAE18	AMAE20
A	1365	1365	1665	1665	1985	1985	2785	2785
B	1080	1080	1080	1080	1080	1080	1080	1080
C	620	620	620	620	620	620	620	620
D	1237	1237	1537	1537	1857	1857	2657	2657
E	570	570	570	570	570	570	570	570

CMEH dry cooler

CMEH20/CMEH30

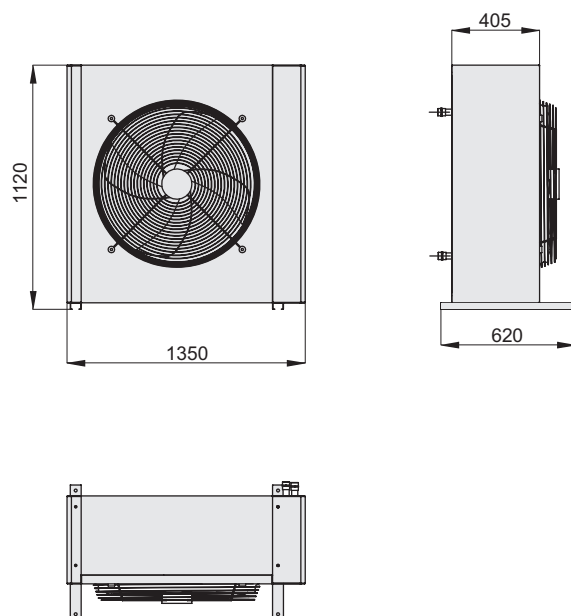

CMEH40/CMEH50/CMEH60

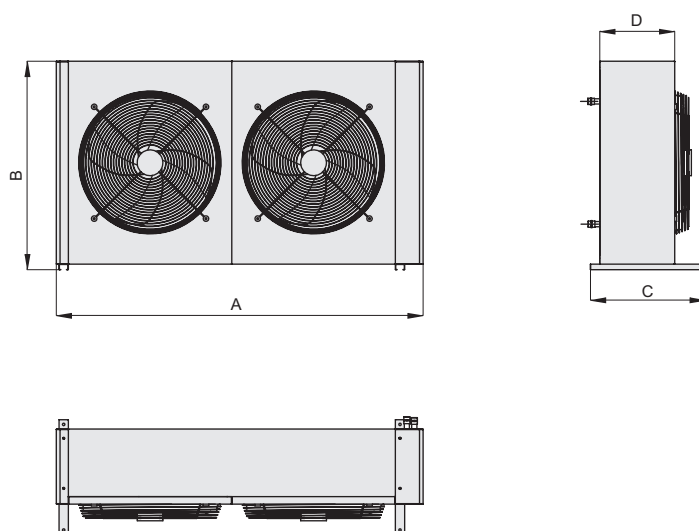

	CMEH40	CMEH50	CMEH60
A	1540	2400	2400
B	1070	1135	1135
C	620	630	630
D	1437	2160	2160

CMEH70/CMEH80

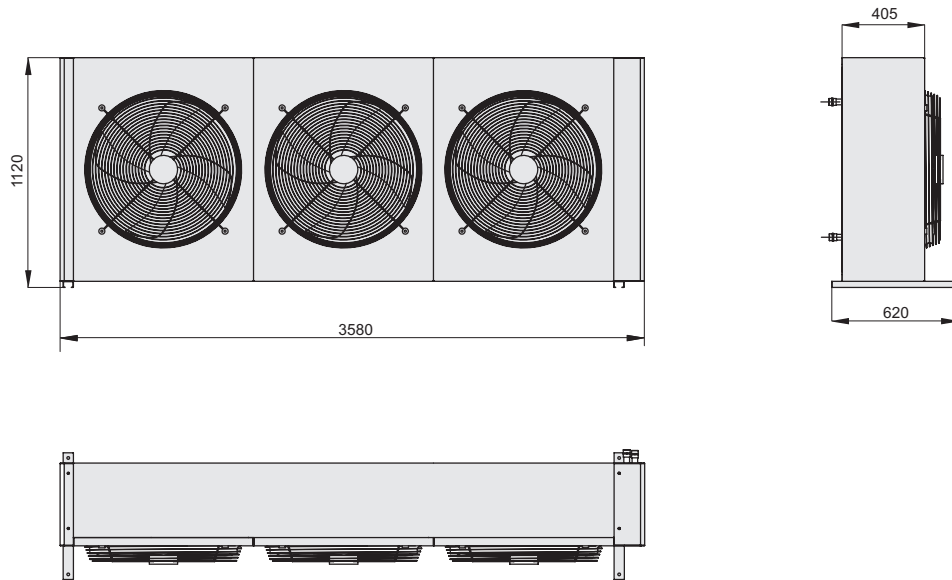

PUG Pump group

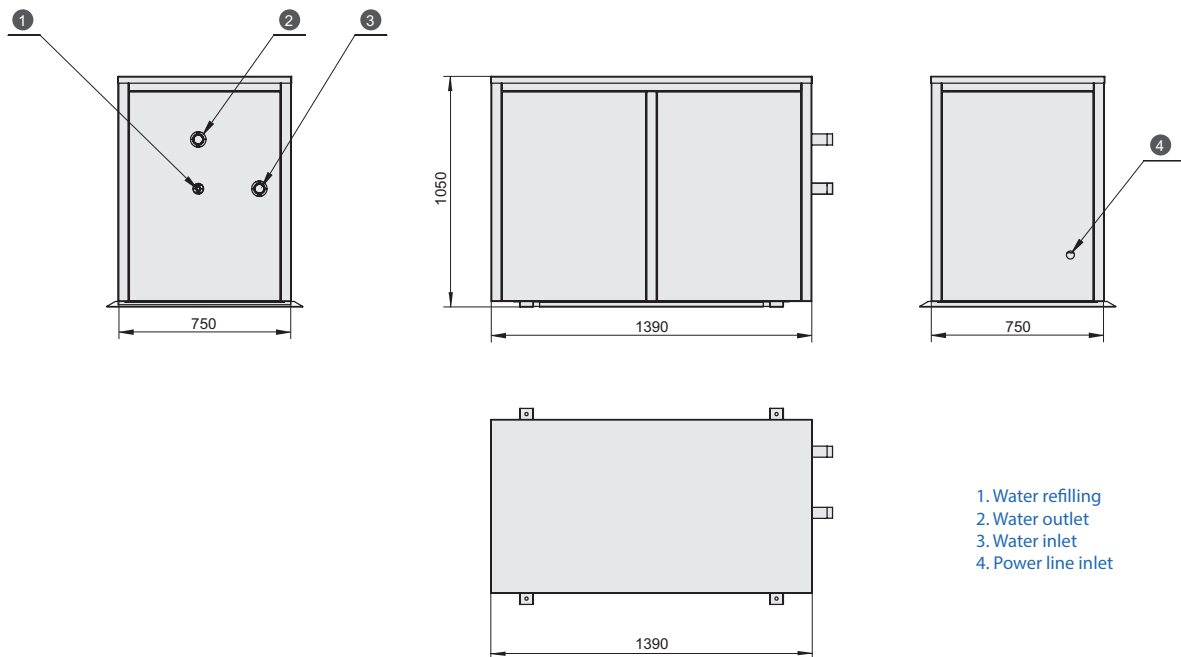



AIRSYS

Airsys Refrigeration Engineering Technology (Beijing) Co., Ltd.

Add: 10th floor, Hongkun Shengtong building, 19, Ping Guo Yuan Xi Xiao Jie, Shijingshan, Beijing, China 100043
Tel: +86(0)10 68656161

Gu'an Airsys Environment Technology Company Ltd.

Add: 25, Dongfang Street, Gu'an Industry Park, Langfang City, Hebei Province, China
Tel: +86(0)10 68656161

Shanghai Airserve HVAC System Service Co., Ltd.

Add: #7-2, No.658, Daduhe Rd., Putuo District, Shanghai, China, 200333
Tel: +86(0)21 62452626 Fax: +86 (0)21 62459622

AIRSYS Australia Sales Office

Add: PO BOX 1088, Flagstaff Hill, SA, 5159, Australia
Tel: +61 479151080

AIRSYS BRASIL LTDA.

Add: Av. Moaci, 395 Conj 35/36 04083-000 – Planalto Paulista SAO PAULO – SP
Tel: +55 (11) 25976817 / +55 (11) 21585560

AIRSYS Deutschland GmbH

Add: FeringasträÙe 6, 85774 Unterföhring, München, Germany
Tel: +43 676 5516510

AIRSYS Klima Sanayi ve Ticaret A.Ş.

Add: Barbaros Mah. Evren Cad. Erzurumlular Sk. No:23 Ataşehir / Istanbul Turkey
Tel: +90(216) 4706280 Fax: +90(216) 4706290

AIRSYS North America, LLC

ICT Cooling:

Add: Spartanburg, South Carolina, USA
Tel: +1 805 3127536

Callcenter:+1 855 8745380

Medical Cooling:

Add: 3127 Independence Dr Livermore, CA 94551, USA
Tel: +1 800 7131543

AIRSYS Singapore Pte. Ltd

Add: 12 Lorong Bakar Batu #06-01 Singapore (348745)
Tel: +65 62787188 Fax: +65 68416301

AIRSYS (UK) Ltd.

Add: 245 Europa Boulevard, Warrington, UK. WA5 7TN
Tel: +44 (0) 1925 377 272 Call Centre: +44(0)8456099950

www.air-sys.uk

Product design and specification subject to change without prior notice.